

HPM420W Submersible Level Transmitter



Nanjing Hangjia Electronic Technology Co., LTD

Overview

HPM420W split-type submersible liquid level transmitter uses high performance silicon piezoresistive pressure sensor as a measuring element, which accurately measure the hydrostatic pressure that is proportional to the liquid level and depth and convert it into a standard (current or voltage) signal output through the signal conditioning circuit, establishing a linear correspondence between the output signal and the liquid depth, and realizing the measurement of the liquid depth.

The product is high precision and small size. Probe can be directly put into the liquid to measure the liquid height from the end of the transmitter to the liquid level. It is easy to use and is suitable for liquid level measurement and control in the fields of petroleum, chemical industry, power plants, urban water supply, and hydrological exploration etc.

The product has been screened for long-term age and stability before delivery. It is reliable and stable and can be used in open spaces with harsh environments.

Features

- ◆ Split-type structure
- ◆ IP68 rated level probe
- ◆ On-site display
- ◆ Wide measurement range, from 1 meter to 300 meters
- ◆ Multiple output signal options
- ◆ Optional lightning protection

Applications

- ◆ Rivers and lakes
- ◆ Pools and water tanks
- ◆ Groundwater, water level monitoring, urban water supply and drainage, etc.
- ◆ Water treatment industry
- ◆ Marine

Technical Parameters

Pressure Range	0~1...300mH ₂ O Note: The measurement unit can be converted into ftH ₂ O@4°C, inH ₂ O@4°C, m, mm, etc. Gives the density value of the measuring medium when the unit is m, mm, etc.
Overload	1.5 times pressure range of full scale
Measuring Medium	Various liquid compatibles contact materials
Output Signal/Power Supply (option 1)	4~20mA / V _S =8~30V
Output Signal/Power Supply (option 2)	4~20mA+HART / V _S =12~32V
Output Signal/Power Supply (option 3)	0~10V / V _S =12~30V

Output Signal/Power Supply (option 4)	Modbus-RTU/RS485 / Vs=12~30V
Output Signal/Power Supply (option 5)	2-way relay / Vs=18~32V
Note: For products with 4~20mA+HART signal output, a measurement range of up to 20 meters is recommended.	
Accuracy	±0.5%FS (typical, @25°C), ±0.2%FS (optional, @25°C)
Long-term Stability	±0.25%FS/year (0.5G) ±0.2%FS/year (0.2G)
*Accuracy complies with IEC 60770 (non-linearity, hysteresis, repeatability)	
Compensation temperature range	0~70°C (0.5G typical accuracy) -10~80°C (0.2G optional accuracy) Note: Please consult for measuring range ≤2mH ₂ O
Temperature Coefficient of Zero	±1.0%FS (Reference 25°C, in compensation temperature range) (Range≤2mH ₂ O,±1.5%FS,0~70°C)
Temperature Coefficient of Full Scale	±1.0%FS (Reference 25°C, in compensation temperature range) (Range≤2mH ₂ O,±1.5%FS,0~70°C)
Operation Temperature	-20~80°C
Medium Temperature	-40~80°C
Storage Temperature	-20~85°C
Protection Grade	IP68(for probe) IP65(for junction box)
Insulation resistance	>20MΩ, 500VDC
Insulation strength	<2mA @ 500VAC (500VAC 50Hz test voltage applied, no breakdown or arcing for 1 minute)

Structure Material

Code	Part	Note
S4	Probe shell material	304
S6		316L
Ti		titanium or titanium alloy
A12	Junction box material	Cast aluminum alloy ADC12 (default)
M1	Pressure sensor	Silicon Piezoresistive, 316L
M2		Silicon Piezoresistive, titanium & titanium alloy
FK	Pressure sensor sealing ring	FKM (working temperature: -20~200°C)
NB		NBR (working temperature: -40~120°C)
C2U	Cable	PU, external diameter (7.2±0.2) mm
C2N		NBR, external diameter (7.2±0.2) mm
M	Filter cap	Metal Material
P		Plastic material

Structure Drawings

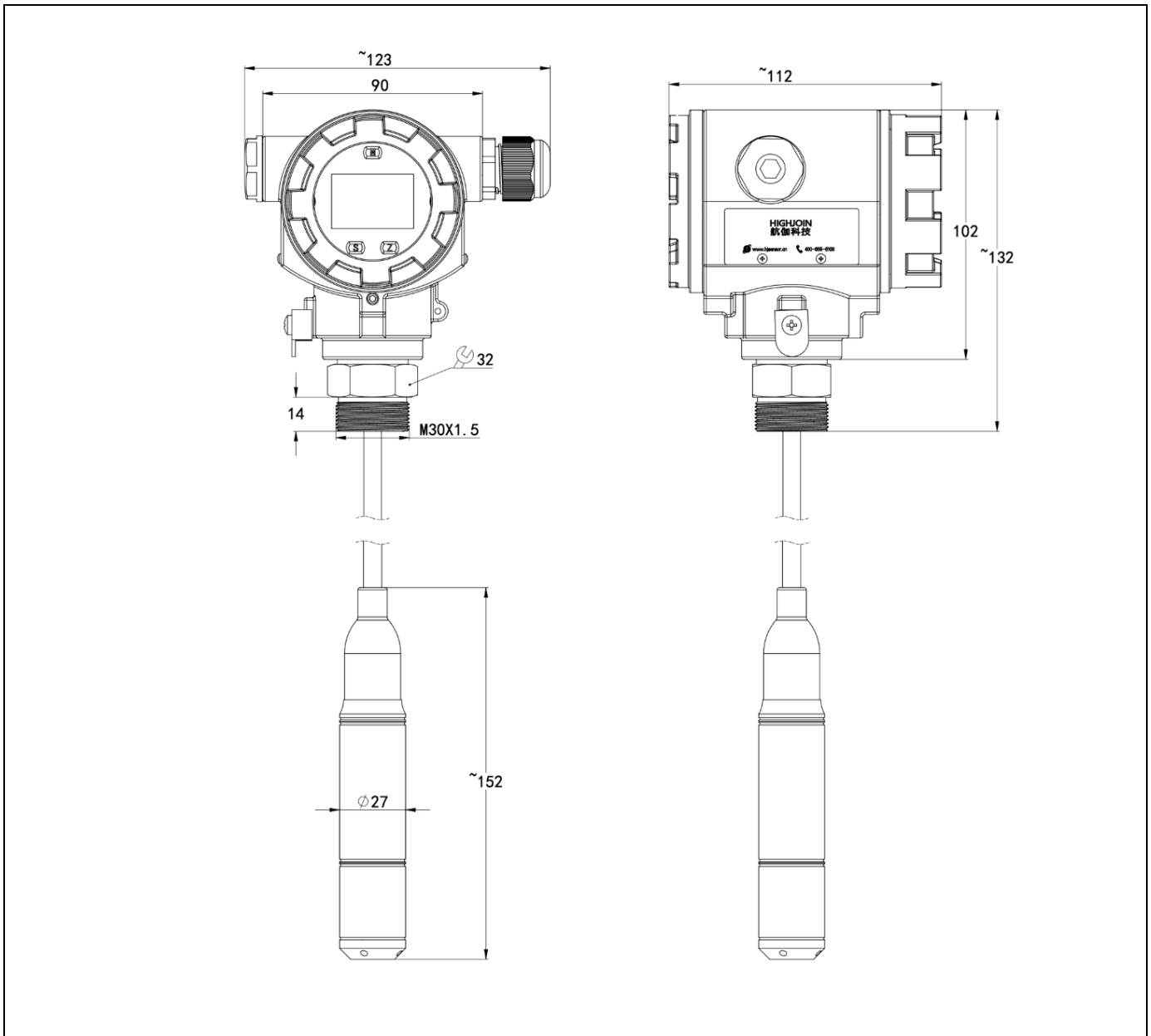

Electrical Connection

2-wire, 4~20mADC or 4~20mADC +HART

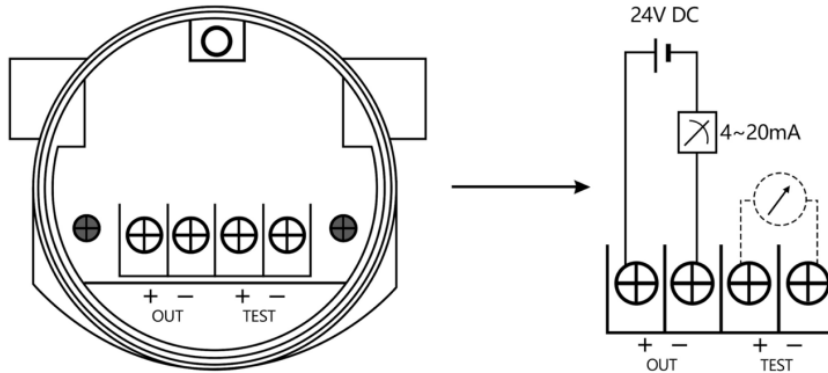

Signal Definition	Power+(+V)	Power-(0V/+OUT)
Terminal Connector	OUT+	OUT-

3-wire, 0~10VDC

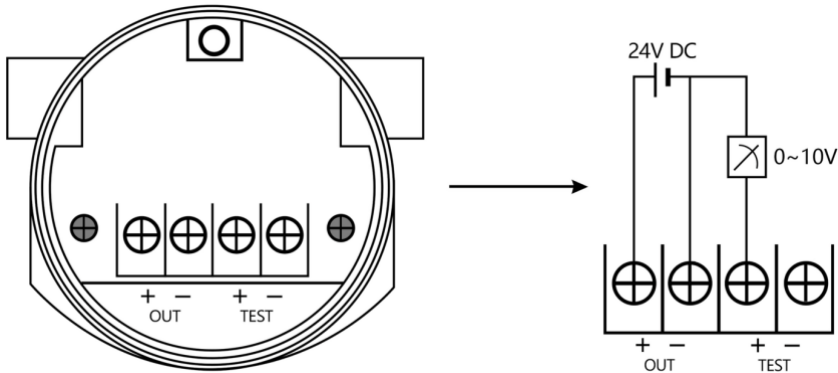

Signal Definition	Power+(+V)	Power-(GND)	Signal +(+OUT)
Terminal Connector	OUT+	OUT-	TEST+

4-wire, Modbus-RTU/RS485

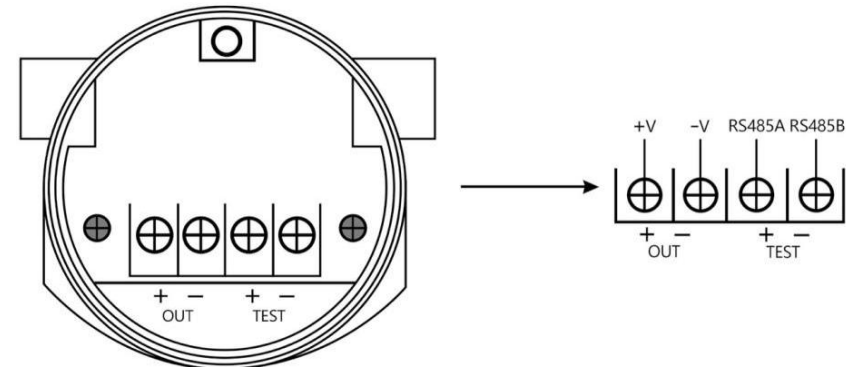

Signal Definition	Power+(+V)	Power-(-V)	RS485A	RS485B
Terminal Connector	OUT+	OUT-	TEST+	TEST-

Installation

Installation in still water (liquid tank, pool, deep well, etc.)

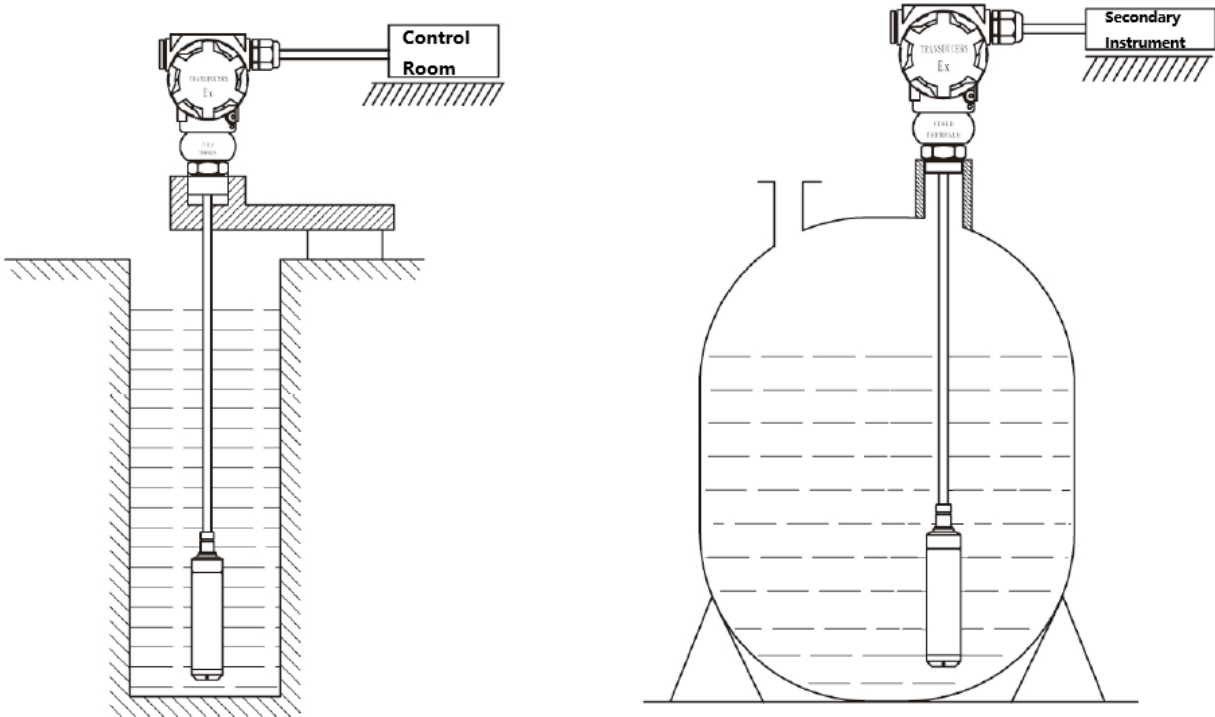

Installation tips:

1. When measuring the static liquid level in an open tank, put the liquid level transmitter vertically into the bottom of the container, and fix the transmitter's cable and junction box at the top of the tank.
2. When installing it in the open air, try to place the junction box of the liquid level transmitter in a ventilated and dry place to avoid direct sunlight and rain.

Install in running water

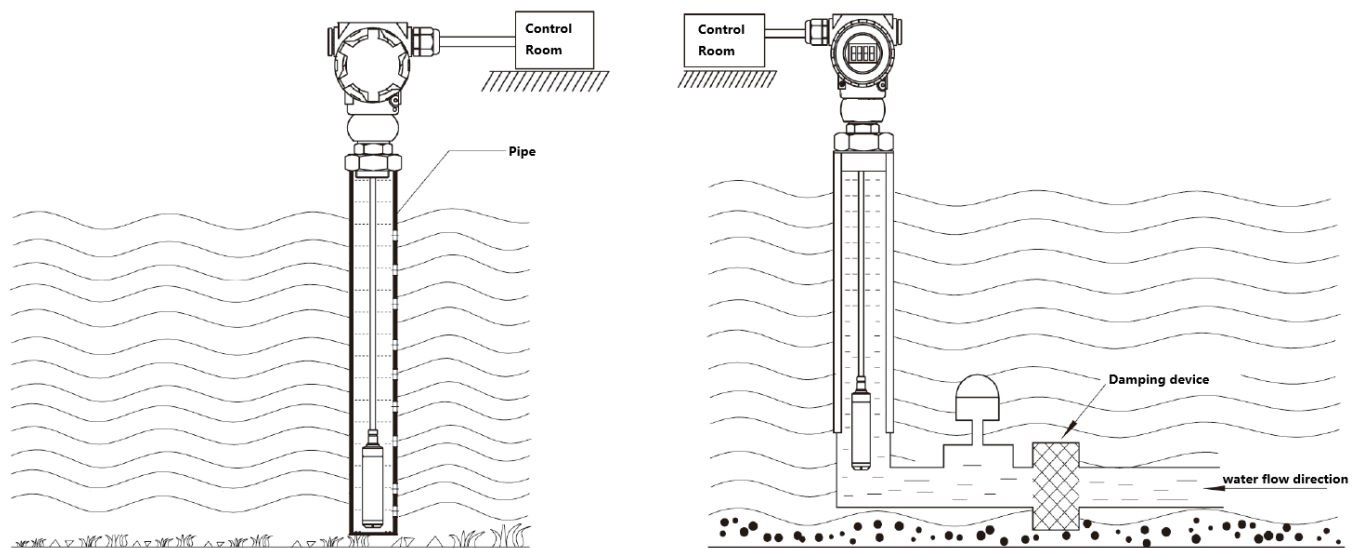

Installation tips:

1. When measuring the water level in flowing water, if the medium fluctuates greatly, a steel pipe with an inner diameter of about 50 cm can be inserted into the water, and several small holes of about $\varnothing 5$ mm can be opened at different heights in the opposite direction of the flow direction to allow water to enter the pipe. Fix the cable wire and junction box at the opening of the tube.
2. When the medium fluctuates greatly and the sediment is large, you can also install a damping device to filter the sediment to eliminate the instability of dynamic pressure and waves.
3. When installing it in the open air, try to place the junction box of the liquid level transmitter in a ventilated and dry place to avoid direct sunlight and rain.
4. When installed in areas with frequent thunderstorms, it is recommended that users install lightning protection devices and ensure that the product and power supply are reliably grounded to reduce the probability of product damage by lightning.

Ordering Guide

Model No.	Type						
HPM420W	Submersible Level Transmitter						
	Level Range	Measuring Range					
	(0 ~ X)mH ₂ O (Ln)	X is the level range Ln is the cable length					
		Code	Output Signal				
		B1	(4 ~ 20)mA				
		B3	(0 ~ 10)V				
		B7	RS485				
		B9	Relay				
		Code	Cable material				
		C2N	NBR Nitrile				
		C2U	PU polyurethane				
		Code	Mounting				
		M30	M30×1.5				
		F25	DN25 flange				
		F50	DN50 flange				
		Code	Sensor				
		M1	316L, silicone piezoresistive				
		M2	Titanium, Silicon piezoresistive				
		Code	Probe material				
		S4	304				
		S6	316L				
		Ti	Titanium or titanium alloys				
		Code	Others				
		QF	Factory report				
		R1	CE qualification				
		J5	0.5G (by default)				
		J2	0.2G				
		FL	lightning protection				
		M	Metal filter cap				
		P	plastic filter cap				
		FK	FKM sealing ring				
		NB	NBR sealing ring				
			Other customization requirements				
eg: HPM420W	(0 ~ 5)mH ₂ O (L7)	B1	C2U	M30	M1	S4	J5 M FK

Certification Information

Factory certification	
Certification organization	CQM
Quality management system	ISO 9001:2015
Certification scope	Research, development and manufacture of pressure transmitter and temperature transmitter
Certificate No.	00223Q21711R1S

CE	
Certification organization	ECM
Certification scope	Pressure Transmitter
Standard	2014/30/EU
Certificate No.	6G241223.NHEWC83